

META **MEC**

Electronic Motor Protection Relay(EMPR)



LG Industrial Systems

www.lgis.com

Electronic Motor Protection Relay

Inverse time characteristics type(GMP 22/40/80)

Complete combination with GMC series Magnetic Contactors

EMPR	Magnetic contactors
GMP22-2P/3P/3PR	GMC-9, GMC-12, GMC-18, GMC-22
GMP40-2P/3P/3PR	GMC-32, GMC-40
GMP80-2S/3S/3SR	GMC-50, GMC-65, GMC-75, GMC-85

Various protect functions

Model	Protection				
	Over current	Phase failure	Stall	Asymmetry	Reverse phase
2P/2S/2T	●	●	●	—	—
3P/3S/3T	●	●	●	●	—
3PR/3SR/3TR	●	●	●	●	●

- Over current protection : Operate according to the inverse time characteristic curve
- Phase failure protection : Trip within 3 seconds when the phase failure rate is over 70%
(Note:When it is 2CT model, only two-phase protection is available)
- Stall protection : Operate according to the inverse time characteristic curve
- Asymmetry protection : Trip within 5 seconds when the phase failure rate is over 50%
- Reverse phase protection : Trip within 1 second

Common use of the Screw type and Tunnel type

If you remove the screw holder, you can use it as tunnel type wiring (Applicable to various installation and wiring method)

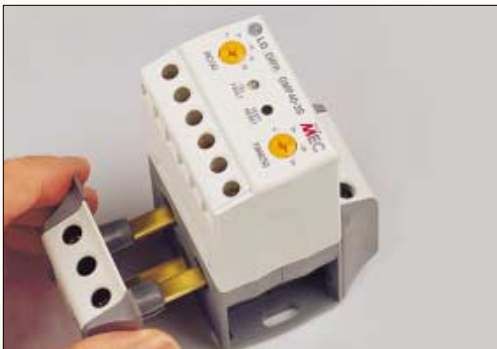

Various installation method

35mm Din rail mounting is available with additional mounting bracket (Optional)



Indicate the cause of the fault by the LEDs

When it is tripped, we can check the causes of the fault by seeing the LED on it and we can troubleshoot the causes in a short time

Condition		Red O.L LED	Green Fault LED	Note
Operation	Normal	Off	Off	
	Overcurrent	On & Off	Off	0.4 second interval
	Over-current	On	Off	
Trip	Phase failure (3CT)	R On	On & Off	1 Times for 3second
		S On	On & Off	2 Times for 3second
		T On	On & Off	3 Times for 3second
	Phase failure(2CT)	On & Off	Protect 2phases of 3phases, trips within 3sec.	
Reverse phase(3CT)	On & Off	On & Off	One after the other	

Complete digital type motor protection relay with built-in MCU(Micro-processor Control Unit)

Real time data processing and high accuracy increase the reliability

Applicable to the Inverter circuit







It is strong against the harmonic distortion and applicable to the inverter control circuit
(Frequency range:20~200Hz, exclude the reverse phase model)

With inverse time characteristics, it is adequate to protect a motor

It has inverse time characteristics (the operating time change according to the value of the over current) and excels in motor protection use

Compact size and elegant outlook

With compact size and elegant outlook, it makes the polished and high class brand image

Ratings							
Model		GMP22-2P	GMP-22-2P(1a1b) GMP22-3P/3PR	GMP 22-2S	GMP22- 3S/3SR	GMP 22-2T	GMP22- 3T/3TR
Type		Pin type		Screw type		Tunnel type	
No. of CT		2CT	2CT 3CT	2CT 3CT		2CT 3CT	
Protection	Overcurrent	●	● ●	● ●		● ●	
	Phase failure	● Note1)	● ●	● ●		● ●	
	Stall	●	● ●	● ●		● ●	
	Asymmetry	—	— ●	— ●		— ●	
	Reverse phase	—	— ●(3PR)	— ●(3SR)		— ●(3TR)	
Current setting range(A)		0.3~1.5		1~5		4.4~22	
	Operating time characteristics	Inverse time characteristics					
	Time setting (sec)	Inverse time	0~30 sec				
Reset time		Manual reset (Prompt) Reset after 1 Min. (Optional)					
Tolerance	Current	±5%					
	Time	±5%(or±0.5sec)					
Control power	Voltage	AC 110V/220V(±10%)		AC 100~260V			
	Frequency	50/60Hz					
Aux. contact	Contact	1SPDT(1c) Note2)		2SPST(When power applied, 1a1b)			
	Ratings	5A/250VAC Resistive load		3A/250VAC Resistive load			
	Operate	(95-†-96 Close)		(95-†-96 Close)		(97-†-98 Open)	
Insulation resistance		Min 100MΩ at 500Vdc					
Surge endurance(IEC 1000-4-5)		1.2×50μs 6kV Apply the standard wave					
Fast transient burst(IEC 1000-4-4)		2.5kV/5min.					
Environment Temperature	Operation	-25~70°C					
	Storage	-30~80°C					
	Relative humidity	30~90%RH(No freezing)					
Trip indicator		Red LED	Red/Green LED	Red LED	Red/Green LED	Red LED	Red/Green LED
Dimension(mm) W×H×D		44×71×78	53×77.5×87.5	53×68×87.5		53×38×87.5	
Mounting type		Direct mount onto a MC			Separate mount(Screw or Din-rail) Note3)		
Applied MC		GMC-9, GMC-12, GMC-18, GMC-22					
Certification		UL, cUL, CE					

[Note1\)](#) When it is 2CT model, only two-phase protection is available [Note2\)](#) 1a1b Aux. switch is optional in GMP 22-2P model [Note3\)](#) The bracket for Din-rail mount is optional

Operating and setting method

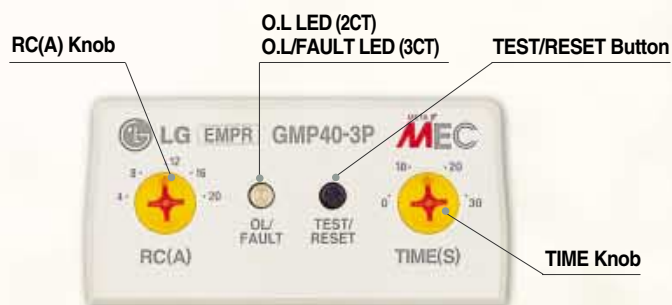

1. Check the rated voltage and apply the control power to A1 and A2 terminal

Do not apply 220V to 110V use model

2. Check the TEST/RESET button operation

Check the operation of the output contact

- 1) Check if the control voltage and wiring method is correct (Refer to the wiring diagram)
- 2) When you press the 'Test/Reset' button, the O.L LED is turned on and the EMPR is tripped
- 3) When you press the 'Test/Reset' button under the EMPR is tripped, the O.L LED is turned off and the EMPR is reset
- 4) Auto reset function: When it is tripped by the over current, it is reset after 1 Min.(Optional)

Caution) For safety, when the motor is operating the 'Test/Reset' button do not work

Ratings



Model	GMP40-2P	GMP40-3P/3PR	GMP40-2S	GMP40-3S/3SR	GMP40-2T	GMP40-3T/3TR	GMP80-2S	GMP80-3S/3SR
Type	Pin type		Screw type		Tunnel type		Screw type	
No. of CT	2CT	3CT	2CT	3CT	2CT	3CT	2CT	3CT
Protection	Overcurrent	●	●	●	●	●	●	●
	Phase failure	●	●	●	●	●	●	●
	Stall	●	●	●	●	●	●	●
	Asymmetry	—	●	—	●	—	●	●
	Reverse phase	—	●(3PR)	—	●(3SR)	—	●(3TR)	—
Current setting range(A)	4~20						16~80	
	8~40							
Operating time characteristics	Inverse time characteristics							
Time setting (sec)	Inverse time	0~30 sec						
	Reset time	Manual reset (Prompt) Reset after 1 Min.(Optional)						
Tolerance	Current	±5%						
	Time	±5%(or±0.5sec)						
Control power	Voltage	AC 100~260V						
	Frequency	50/60Hz						
Aux. contact	Contact	2SPST(When power applied, 1a1b)						
	Ratings	3A/250VAC Resistive load						
	Operate	(95+/- 96 Close)			(97+/- 98 Open)			
Insulation resistance	Min 100MΩ at 500Vdc							
Surge endurance(IEC 1000-4-5)	1.2×50μs 6kV Apply the standard wave							
Fast transient burst(IEC 1000-4-4)	2.5kV/5min.							
Environment Temperature	Operation	-25~70°C						
	Storage	-30~80°C						
Relative humidity	30~90%RH(No freezing)							
Trip indicator	Red LED	Red/Green LED	Red LED	Red/Green LED	Red LED	Red/Green LED	Red LED	2 Red LEDs
Dimension(mm) W×H×D	53×77.5×87.5		53×68×87.5		53×38×87.5		89×77.5×97.4	
Mounting type	Direct mount onto a MC		Separate mount(Screw or Din-rail)				Direct/Separate mount (Screw or Din-rail) Note1	
Applied MC	GMC-32, GMC-40						GMC-50, GMC-65, GMC-75, GMC-85	
Certification	UL, cUL, CE							

3. Set the operating time

The operating time is set on the base of 600% of the rated current in the characteristic curve

- 1) Set the operating time by considering the operating time and start current according to the types of the load
(Ex.: If the start current is 600% of the normal operation current and the starting is 10sec, set the time knob around 11~12sec. with 10~20%margin)
- 2) Operating time range is 0~30sec
- 3) If the time knob is set to 10sec, the EMPR is tripped when the start current (600% of the rated current) is applied for 10sec

Caution: The EMPR with inverse time characteristics can be tripped to protect the motor when the motor is started a few times continuously
When a motor is frequently changing the rotating direction (forward and reverse), set the operating time longer
For the crane and hoist use, select the EMPR with definite time characteristics

4. Set the operating current

Set the current by considering the rated current of a motor to protect from the over current

- 1) Check if the rated current of a motor is within the current setting range of an EMPR
- 2) Set the 'RC' (Rated current) knob to the maximum value and then start a motor
- 3) Under normal motor operation, rotate the 'RC' knob to the counterclockwise until the 'O.L.' LED turned on&off
The current at this point in the 100% current rating under real load
- 4) At this point, rotate the 'RC' knob to the clockwise until the 'O.L.' LED turned off. In general case the setting value is around 110~120% of the rated current
Ex) When the 'O.L.' LED flickering at 20A, the setting current will be 22A(=20x1.1)

[Note1\)](#) The brackets for connection is offered standard

Type	Dimensions (mm)	Weight(2CT/3CT)
GMP22-2P (1c)		0.15kg * Din-rail mount is not available
GMP22-2P (1a1b) GMP22-3P GMP22-3PR		0.18kg * The bracket for Din-rail mount is optional
GMP40-2P GMP40-3P GMP40-3PR		0.20kg/0.22kg * The bracket for Din-rail mount is optional
GMP22-2S GMP22-3S GMP22-3SR GMP40-2S GMP40-3S GMP40-3SR		0.19kg/0.21kg * The bracket for Din-rail mount is optional
GMP22-2T GMP22-3T GMP22-3TR GMP40-2T GMP40-3T GMP40-3TR		0.14kg/0.16kg * The bracket for Din-rail mount is optional
GMP80-2S GMP80-3S GMP80-3SR		0.42kg/0.46kg

Class 5 (5sec.)

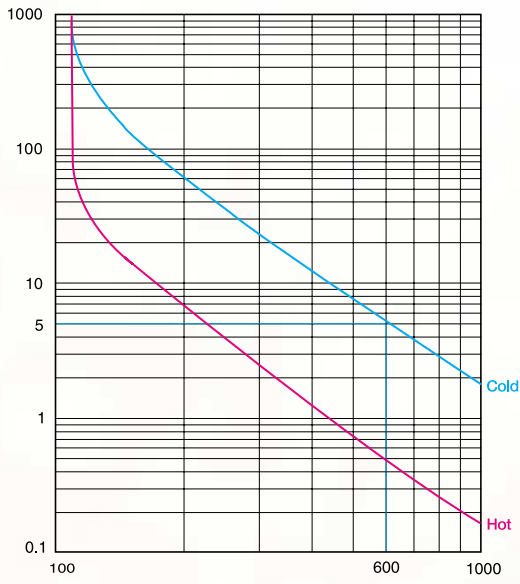

Class 10 (10sec.)

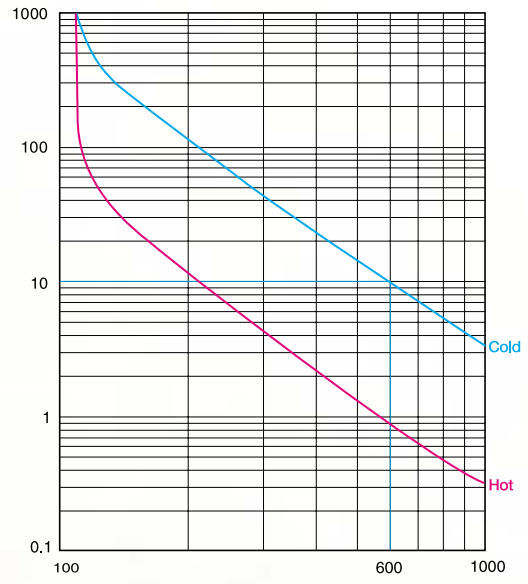

Class 15 (15sec.)

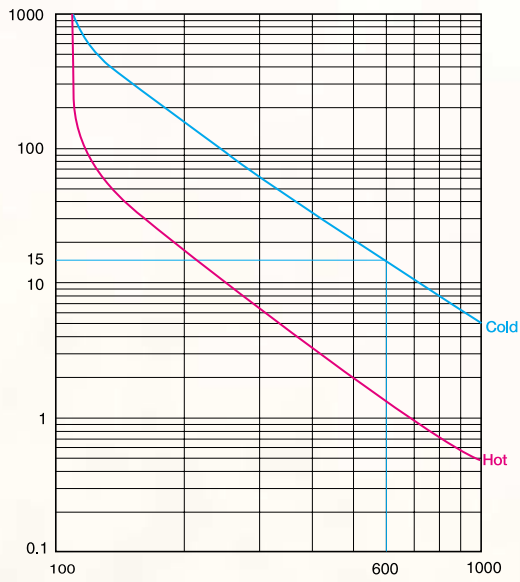

Class 20 (20sec.)

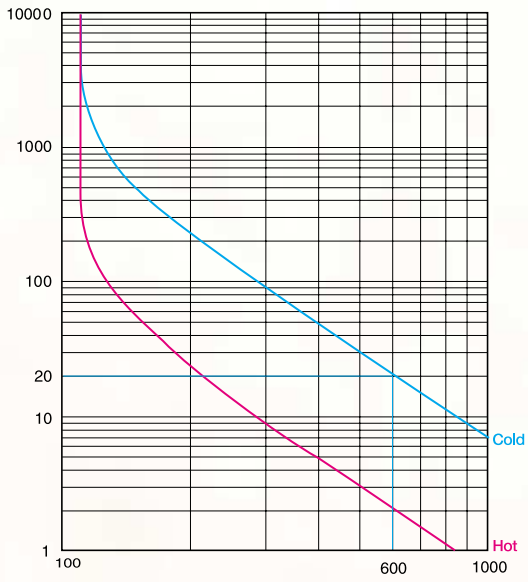

Class 25 (25sec.)

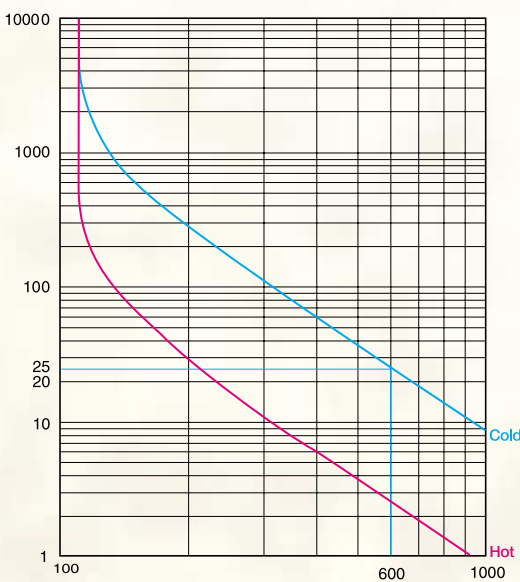

Class 30 (30sec.)

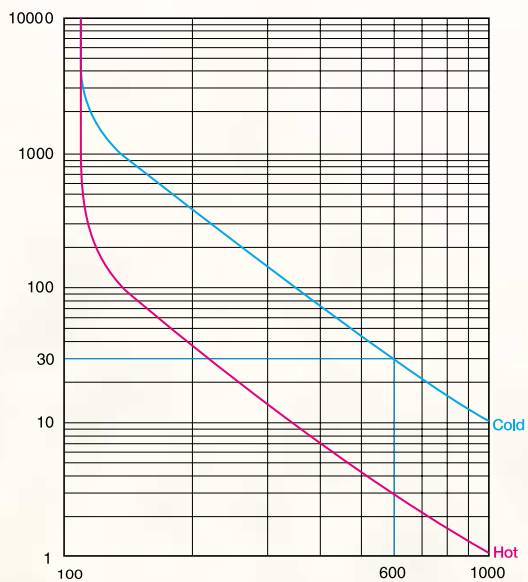

Wiring method

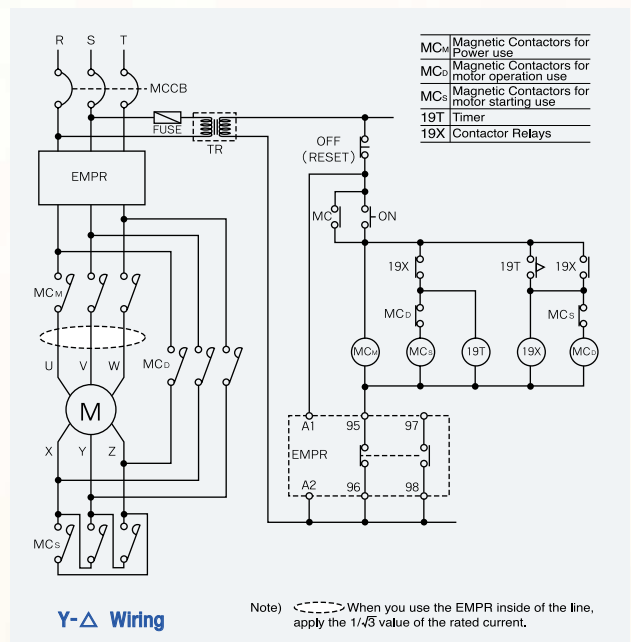
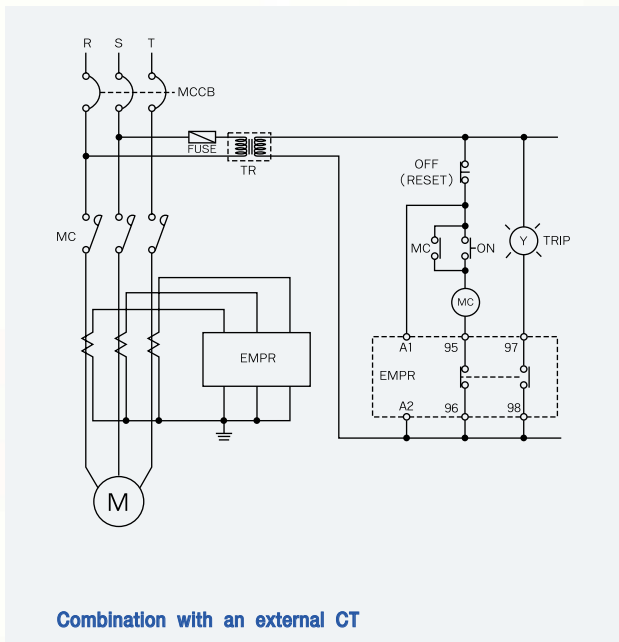
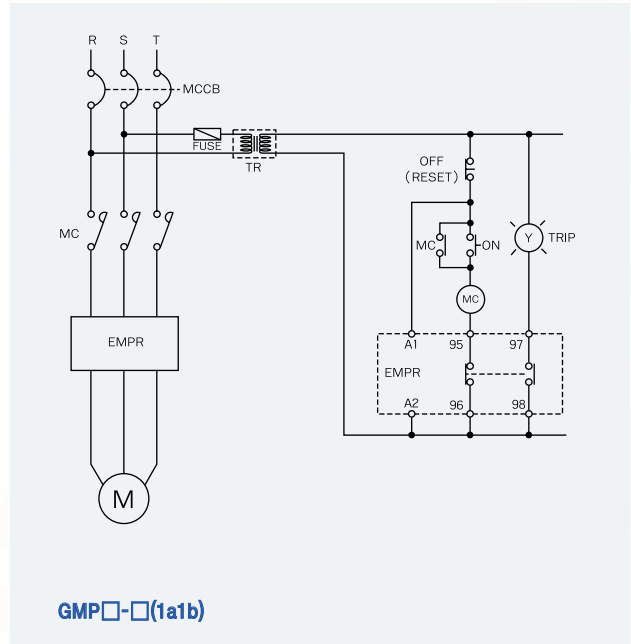
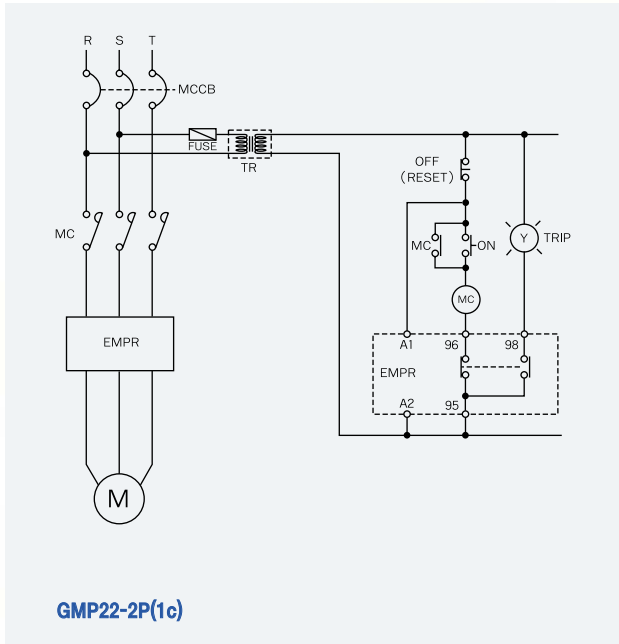

Note) 3CT type EMPR can not be used to the single(1) phase motor.

Contact configurations

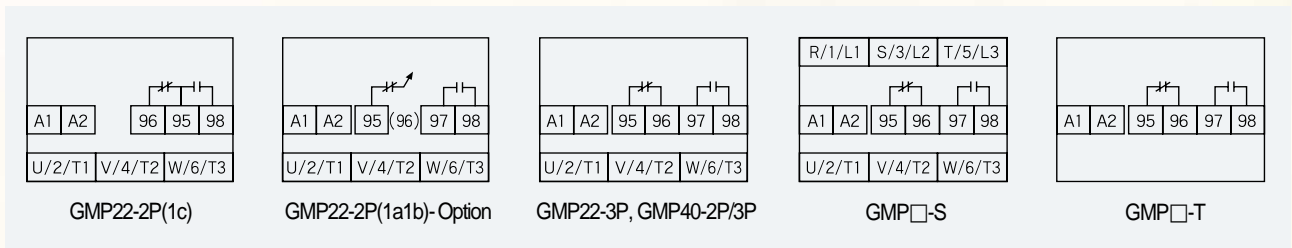

Definite time characteristics type (GMP-60T)

Characteristics

- Small size, economical
- Delay time setting in starting and operation
- Over current, phase failure protection
- Definite time characteristics
- Wide current setting range
- Screw or Din-rail mounting

Protection

- Over current : Trips the over current after setting time
- Phase failure : Under phase failure condition over current flows

The EMPR tripped if it is over the setting over-current



Contact configuration

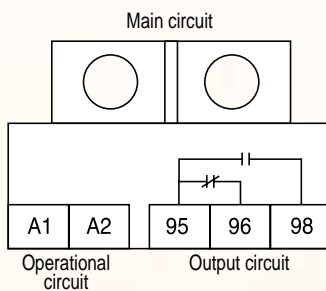

Tunnel type EMPR protects the current under 0.1A

- The tunnel type EMPR with 0.5~6A nominal current, can detect the current under 0.1A
- If we increase the number of times of a wire pass through the CT (Tunnel), the EMPR can detect the lower current

No. of times to pass through	Current setting range
1	0.5~6
2	0.25~3
3	0.17~2
4	0.12~1.5

Ratings (Tunnel type)

Model	GMP60T	
Type	Tunnel type	
No. of CT	2	
Protection	Over current	●
	Phase failure	△ Note1)
	Stall	—
	Asymmetry	—
	Reverse phase	—
Current setting range(A)		0.5~6
		3~30
		5~60
Operating time characteristics		Definite time characteristics
Time setting (sec.)	Starting time	0.2~30
	Operating time	0.2~15
	Reset time	Manual reset
Allowable error	Current	±5%
	Time	±5%(or ±0.5 sec.)
Control power	Voltage	180~260V (110V / 440V) Note2)
	Frequency	50 / 60Hz
Aux. s/w	Contact	1SPDT (1c)
	Ratings	5A 250Vac, resistive load
	Operation	95 ⚡ 96close
Insulation resistance		Min. 50MΩ at 500Vdc
Surge indurance(IEC 1000-4-5)		7kV(6times for 1min. Interval)
Fast transient burst(IEC 1000-4-4)		2.5kV/5min.
Environment Temperature	Operation	-25~70°C
	Storage	-50~80°C
Relative humidity		46~85 RH(No freezing)
Trip indicator		LED
Dimension(mm) W×H×D		72×63×69
Mounting type		Separate mount(Screw & Din-rail)
Applied MC		GMC-9, 12, 18, 32, 40, 50
Certification		UL, CUL, CE

Note) 1) Under phase failure condition over current flows
The EMPR tripped if it is over the setting over current
2) () are optional specifications

● External dimensions

Type	Dimensions(mm)	Mounting dimensions(mm)	Weight(kg)
GMP60T			0.14

● Characteristics curve

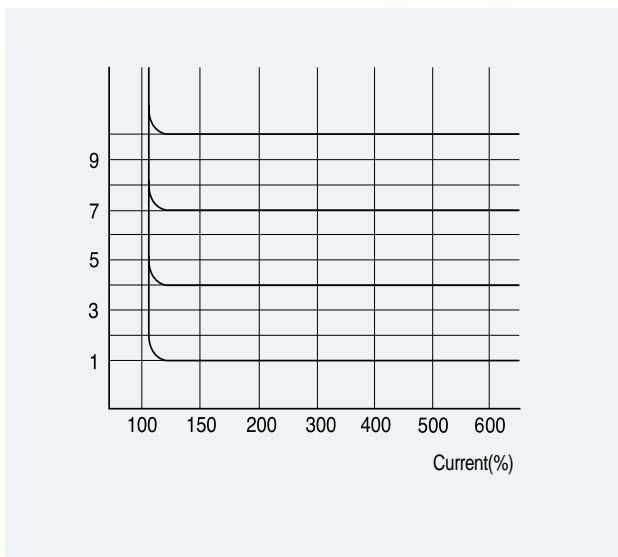

● Wiring method

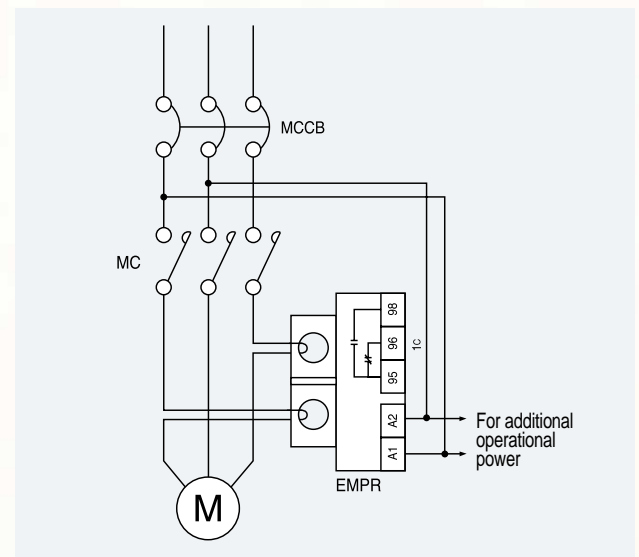

■ CT(Current Transformer)

● Rating

Type	2CT	
Ratio	DCT-100	100 : 5A
	DCT-150	150 : 5A
	DCT-200	200 : 5A
	DCT-300	300 : 5A
	DCT-400	400 : 5A
Class	1.0	
Burden	5VA	
Rated voltage	AC 600V	
Withstand voltage	2kV	
Insulation resistance	10MΩ (DC 500V Megger)	

● Dimension

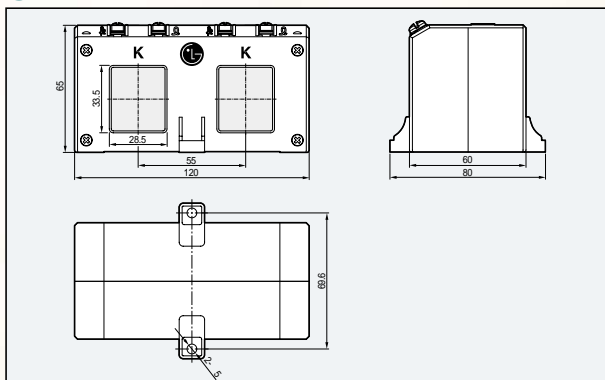

◆ Operation & setting

● Tunnel type mounting

1. Check the Test/Reset button operation

- Check if the EMPR operate in overcurrent
 - ① Check if the wiring is correct (Refer to the wiring diagram)
 - ② Set the 'D-Time' and 'O-Time' knob to the min. ratings
 - ③ When the 'Test' button is pressed under tripped condition, the 'O.L.' LED is turned off
 - ④ When you press the 'Test' button again then the lamp turned off and the EMPR reset

Note) In operation, even though you press the 'Test/Reset' button, the EMPR do not trip

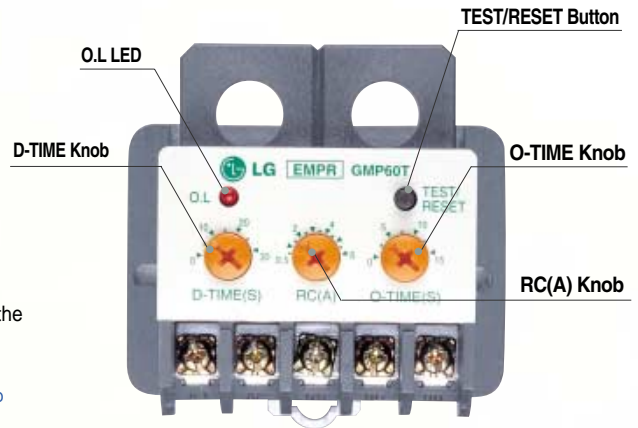

2. Set the operating time (Definite time characteristics)

● D-time (Delay time) : 0.2~30 sec

The motor starting current, which flows when the motor is starting, is generally 600~800% of the rated current and the delay time varies according to the load condition. It is the time during which the EMPR do not operated by over-current during the starting time

- ① Set the delay time by use of the 'D-time' knob
- ② In case you do not know the delay time, start the motor by setting the 'D-time' knob to the max. position and after checking the time during which the starting current become stable, set the D-time (In general pump, the setting time is 3~5 seconds)

Note) The time delay is forced time delay type, therefore if you make a mistake to select the time, the motor may be burn

● The operating time is the time during which the EMPR tripped by the over-current. The EMPR is tripped after the selected operation time

- ① Set the operation time by the 'O-time' knob
- ② In special case such as for mechanical shock relay, if you set the 'O-time' to the min value, the EMPR is tripped at once

Note) Generally set it to 4~6 seconds

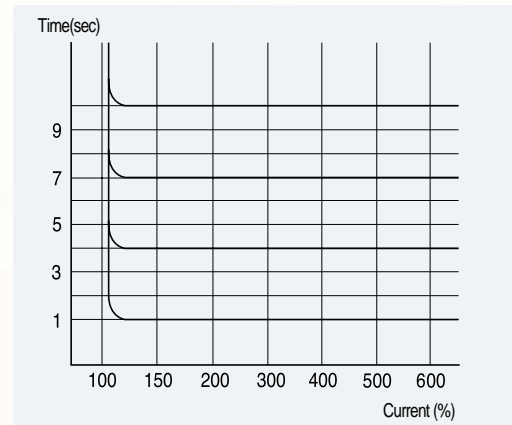

• Definite time characteristics curve

3. Set the operating current (Similar to that of the pin type & screw type)

● Set the operation current to protect from over current. Set the current by considering the rated current

- ① Start the motor by setting the 'RC' knob to the maximum position
- ② Under operating condition, rotate the 'RC' knob to the counterclockwise until the 'O.L.' LED turned on&off. The current at this point is the value (100%) under real load condition
- ③ Rotate the 'RC' knob to the clock-wise until the 'O.L.' LED turned off. In general case the setting is 110~120% of the rated current

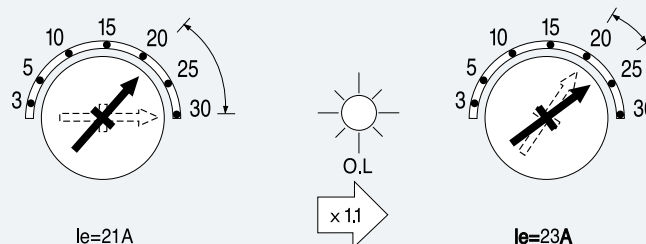

(ex: When the 'O.L.' LED glittings at 21A, the setting current will be 23A (=21*1.1))

4. Check the LED condition when operation

① Over-current

- The EMPR is not tripped during the D-time under over-current but the O.L LED turned on and off to indicate that the over-current flows
- If the EMPR is tripped after D-time the O.L LED turned on

② Phase failure

- If a motor does not rotate under phase failure, the high current may flows.
- At this time a motor is protected by the over-current protection function

Condition	Red O.L LED		Note
Operation normal	Off		
Overcurrent	On&Off		On & Off under over current
Trip over-current	On		The EMPR is tripped

Motor selection

Nominal current	Current setting range(A)	220~240VAC			440~480VAC		
		3 phase motor ratings kW(Hp)		Full load current (A)	3 phase motor ratings kW(Hp)		Full load current (A)
1.5	0.3-1.5	~0.18	(~0.25)	1.5	0.12~0.55	(~0.75)	1.6
5	1-5	0.18~0.75	(0.25~1)	4.8	0.25~1.5	(0.33~2)	4
22	4.4-22	1.1~4	(1.5~5.5)	18.8	3~11	(4~15)	24
20	4-20	0.75~3.7	(1~5)	17.4	2.2~7.5	(3~10)	17
40	8-40	2.2~7.5	(3~10)	34	4~15	(5.5~20)	32.5
80	16-80	4~18.5	(5.5~25)	79	7.5~37	(10~50)	74
06	0.5-6	0.09~0.75	(0.13~1)	4.8	0.09~22	(0.13~3)	5.5
30	3-30	0.37~5.5	(0.5~7.5)	26	1.1~11	(1.5~15)	24
60	5-60	1.1~11	(1~15)	48	3~22	(4~30)	46.5

Note) The above values are the reference ones by AC3 class standard squirrel cage motor.
The values may be changed according to the class and the manufacturer of a motor.

Ordering information (Type designations)

GMP

22 — 2

P

R

220

Frame	Current setting value	Type	CT No.		Wiring method		Reverse phase		Operating voltage	
22	0.3~1.5A	Direct/ Screw/ Tunnel	2	2CT	P	Pin type	-	Without reverse phase protection	-	AC100~260V 220 AC220V
	1~5A		3	3CT	S	Screw type	R	With reverse phase protection		
	4.4~22A		T	Tunnel type						
40	4~20A	Screw								
	8~40A									
80	16~80A	Screw								

Frame	Current setting value	Type	Operating voltage	
60	0.5~6A	Tunnel	24	AC 24V
	3~30A		110	AC85~120V
	5~60A		220	AC180~260V



LG Industrial Systems

■ HEAD OFFICE

LG TWIN TOWERS, 20 Yoido-dong, Youngdungpo-gu,
Seoul, 150-721, Korea
Tel. (82-2)3777-4870
Fax. (82-2)3777-4713
<http://www.lgis.com>

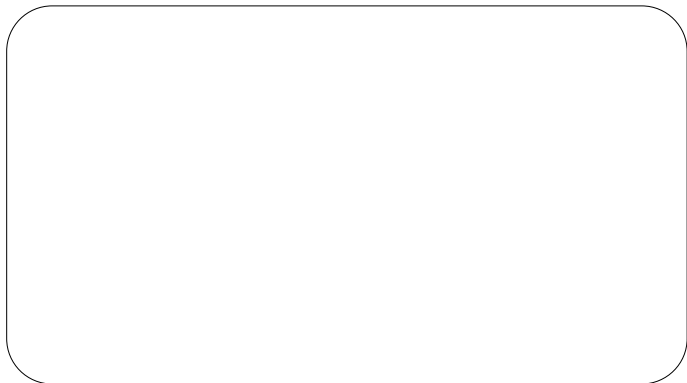

Specifications in this catalog are subject to change without notice due to continuous product development and improvement.

▲ Safety Instructions

- For your safety, please read user's manual thoroughly before operating.
- Contact the nearest authorized service facility for examination, repair, or adjustment.
- Please contact qualified service technician when you need maintenance. Do not disassemble or repair by yourself!
- Any maintenance and inspection shall be performed by the personnel having expertise concerned.

Global network

■ Dalian LG Industrial Systems Co., Ltd China

- Address: No. 15 Liaohexi 3 Road, economic and technical development zone, Dalian, China
- Tel: 86-411-731-8210 ● Fax: 86-411-730-7560
- e-mail: youngeel@lgis.com

■ LG-VINA Industrial Systems Co., Ltd Vietnam

- Address: LGIS VINA Congty che tao may dien Viet-Hung Dong Anh Hanoi, Vietnam
- Tel: 84-4-882-0222 ● Fax: 84-4-882-0220
- e-mail: srjo@hn.vnn.vn

■ LG Industrial Trading (Shanghai) Co., Ltd China

- Address: Room1705-1707, 17th Floor Xinda Commerical Building No 318, Xian Xia Road Shanahai
- Tel: 86-21-6252-4291 ● Fax: 86-21-6278-4372
- e-mail: hgseo@lgis.com

■ LG Industrial Systems Beijing Office China

- Address: Room 303, 3F North B/D, EAS 21 XIAO YUN ROAD, Dong San Huan Bei Road, Chao Yang District, Beijing, China
- Tel: 86-10-6462-3259/4 ● Fax: 86-10-6462-3236
- e-mail: sclim@mx.cei.gov.cn

■ LG Industrial Systems Shanghai Office China

- Address: Room1705-1707, 17th Floor Xinda Commerical Building No 318, Xian Xia Road Shanahai, China
- Tel: 86-21-6278-4370 ● Fax: 86-21-6278-4301
- e-mail: sdhwang@lgis.com

■ LG Industrial Systems Guangzhou Office China

- Address: Room 303, 3F, Zheng Sheng Building, No 5-6, Tian He Bei Road, Guangzhou, China
- Tel: 86-20-8755-3410 ● Fax: 86-20-8755-3408
- e-mail: lgisgz@public1.guangzhou.gd.cn

■ LG Industrial Systems New Jersey Office USA

- Address: 1000 Sylvan Avenue, Englewood Cliffs, New Jersey 07632 USA
- Tel: 1-201-816-2985 ● Fax: 1-201-816-2343
- e-mail: younsupl@lgisusa.com

■ LG Industrial Systems Tokyo Office Japan

- Address: 16F, Higashi-Kan, Akasaka Twin Towers 17-22, 2-chome, Akasaka, Minato-ku Tokyo 107-0052, Japan
- Tel: 81-3-3582-9128 ● Fax: 81-3-3582-0065
- e-mail: snbaek@lgis.com